

ZAXIS
85
US



HYDRAULIC EXCAVATOR

- **Model Code:** ZX85US-3
- **Engine Rated Power:** 39.4 kW (52.8 HP)
- **Operating Weight:** 7 800 - 8 400 kg
- **Backhoe Bucket:** SAE, PCSA Heaped: 0.13 - 0.33 m³
CECE Heaped: 0.12 - 0.29 m³

The Power to Perform

The ZAXIS-3 series is a new generation of excavators designed to provide more efficient power, productivity and improved operator comfort. By listening carefully to the wishes of the end-user, HITACHI not only understands your business, but also provides the reliable solutions you've been looking for.

NEW AND IMPROVED

- **Performance:**
5% higher production
- **Comfort:**
Excellent visibility
Enhanced controllability
Lower noise level
- **New equipment:**
Standard satellite communication system
Standard theft deterrent system
Rear view camera (optional)
- **Reduced running costs:**
Lower fuel consumption per m³
Improved durability and reliability



Boosted Productivity

Short-tail-swing makes possible efficient operations in various confined worksites. Efficient hydraulic system and new intercooled turbocharger diesel engine were developed for ZAXIS-3. These advanced technologies are at work to yield bigger output with higher fuel efficiency.



Applicable in Various Job Sites

Short 1 290 mm rear-end swing radius promises efficient operations in confined spaces.

- *Rear-end swing radius is shorter than of ZX70LC-3.*
- *Short 1 810 mm minimum swing radius.*

Stability Exceeds Standard Model

Stability is increased by using the exclusive US weighted counterweight.

- *Stability: 17% increase (vs. ZX70LC-3)*

*In figure, machines are expressed by model codes for presentation. The photo shows an excavator with a 1.62 m arm installed.

More production, less fuel consumption

Increased Production

A combination of the hydraulic system and new intercooled turbocharger engine allows the efficient use of hydraulic pressure to increase speeds of actuators and boost production with higher fuel efficiency. The productivity is increased 5% in comparison to previous model ZAXIS-1.

E-mode

The E mode and P mode can be selected to suit job needs. The E mode can save fuel consumption by up to 12% compared to the previous model's P mode, while yielding similar production.

Increase in Swing Torque and Traction Force

Swing torque and traction force are increased significantly.

- **Swing torque 9% UP**
- **Traction force 8% UP**

Efficient hydraulic control

Hydraulic System

The Hydraulic System elicits more user satisfaction than other models due to its greater operator comfort and ease of operability. During arm roll-in operations, the hydraulics of 3 pumps are merged, allowing for quick leveling operations. Depending on the operations, usage of the 3 pumps are automatically switched, offering excellent operability. It supports stability and combined operability, such as speed balance and land clearing.

Speed Sensing Control

A speed sensing system is used for hydraulic horsepower control. The hydraulic pump delivery flow, which varies with changes in engine RPM according to the load, is controlled. This means efficient use of engine horsepower, and also contributes to a reduction in fuel consumption.

Development concept of new engine

Intercooled Turbocharger Engine

The new intercooled turbocharger engine is developed and built to comply with the rigorous Emission Regulations enforced in 2008 in U.S and EU. This new engine contributes to environmental preservation. At the same time it realizes high durability and low fuel consumption by adapting the latest advanced engine technology.



Cooled EGR* System

Exhaust gas is partially mixed with intake air to lower combustion temperature for reducing NOx and fuel consumption. What's more, the EGR cooler cools down exhaust gas to increase air concentration for complete combustion, reducing PM** (diesel plume).

*Exhaust Gas Recirculation
**Particulate Matter

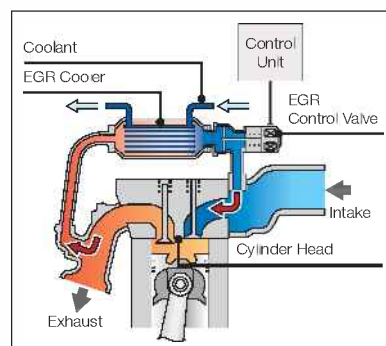

Improved crowding performance

Reshaped Blade (optional)

The blade is reshaped for crowding without loss.

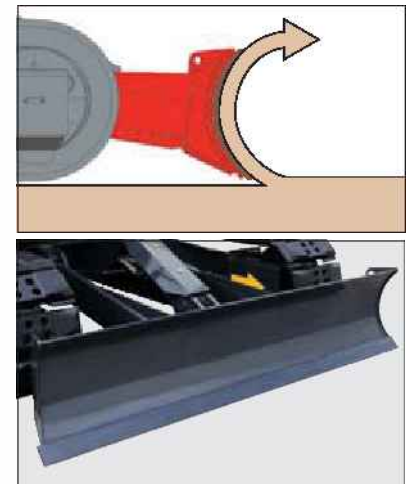

A New Standard in Operator Comfort

The operator's seat of the ZAXIS-3 series gives the operator an excellent view of the jobsite. Ample legroom, short stroke levers and a large seat ensure optimum working conditions for the operator during long hours.

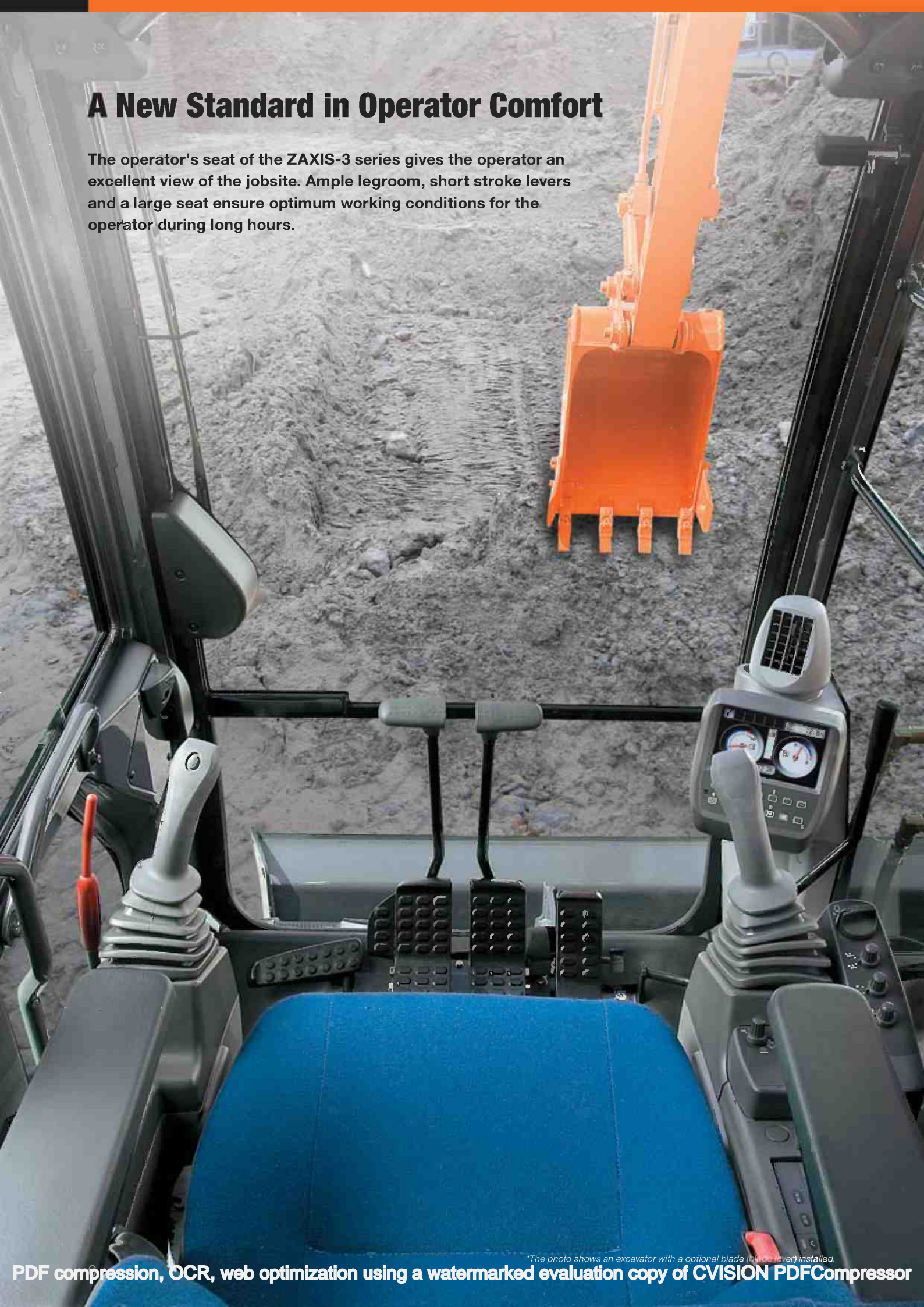

*The photo shows an excavator with a optional blade (blade never) installed.

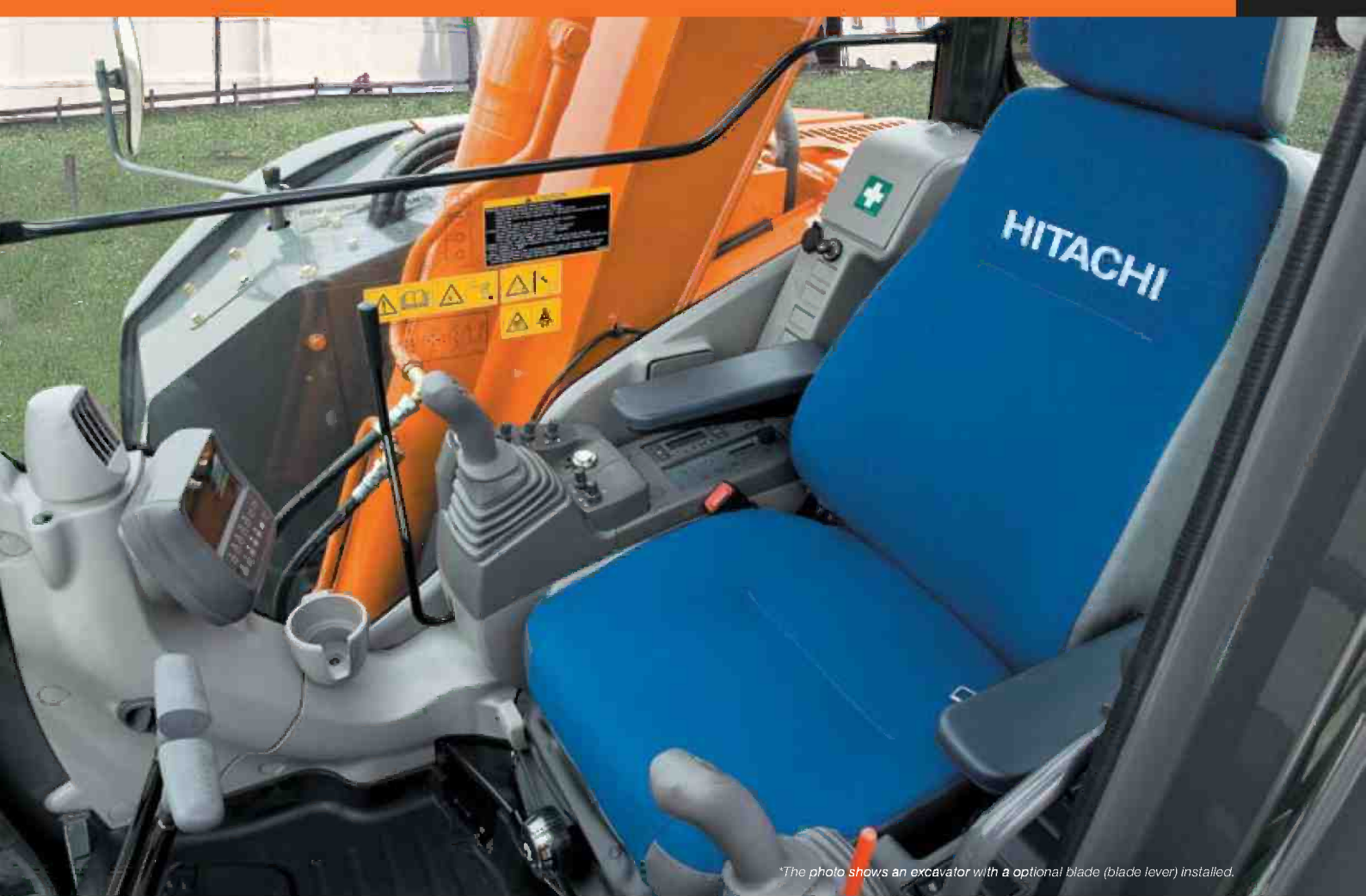

**The photo shows an excavator with a optional blade (blade lever) installed.*

The ZAXIS-3 series cab has been redesigned to meet demands of customers. From the operator's seat the operator has an excellent view of the jobsite. On the widescreen color LCD monitor the operator can see machine conditions and with the rear view camera (optional), what is behind the machine. Ample legroom, short stroke levers and a suspension seat with heating ensure optimum working conditions. The seat features horizontal, vertical adjustments and has a backrest contoured for comfort, with a HITACHI logo.



Wide adjustable armrests and a retractable seat belt are included. Short stroke levers allow for continuous operation with less fatigue. Three switches on the lever (optional) can be set to operate attachments other than buckets. The cab is pressurized to keep out dust. Noise and vibrations are kept to a minimum due to the elastic mounts, filled with silicone oil, the cab rests on.

Visibility is improved especially for the right downward view. Sliding windows on the front and side enable direct communication between operator and other workers. Visibility is increased with the optional blade. The blade is shaped so that the operator can visually confirm that the blade is in contact with the ground. A flat floor allows for easy cleaning. Ergonomic controls and switches, fully automatic air conditioner and a radio complete the package.

Embedded Information Technology

The ZAXIS-3 series is equipped with a widescreen color LCD monitor with adjustable contrast for day and night shifts. With the monitor the operator can check maintenance intervals and connect to the rear view camera (optional). A theft deterrent system and multi-language selection is also available.

Multi function monitor



The color LCD monitor, located in the cab, indicates coolant temperature, fuel level, and maintenance data. The display can also be adjusted to day or night shift.

Maintenance support

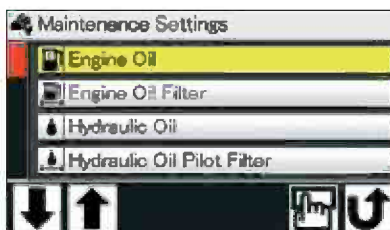

Replacement timing of hydraulic oil and fuel filters is alerted to the operator through the LCD monitor according to the schedule preset by the user each time when turning the key switch. The scheduled maintenance can prevent the failure of the machine.

Multi-language selection



The menu allows selection from 12 languages.





Rear view camera (optional)



Theft deterrent system

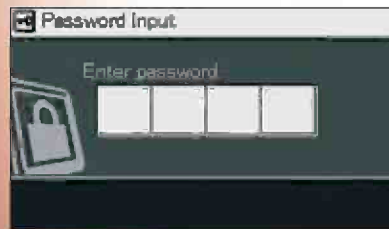

The electronic immobiliser requires the entry of a password to the multifunction monitor each time when starting the engine to prevent theft and vandalism.

The widescreen color LCD, in tandem with the rear view camera on the counterweight, provides a convenient view of the area behind the unit. The rear view camera automatically works when travelling backward, and can also be manually turned on with a select switch on the monitor.



ZX85US-3 off-set front

A Solid Base for a Long Life

HITACHI's technology is built on a wealth of experience and know-how from a variety of demanding conditions around the world. The undercarriage of the ZAXIS 85US has become much stronger. Improved construction and enlarged box sections make this machine more durable.



Strengthened Upperstructure

The new ZAXIS excavator now has a D-section frame skirt, which was highly acclaimed in previous models. As a result of this D-section frame skirt, rigidity and durability in the upper machinery are greatly improved.

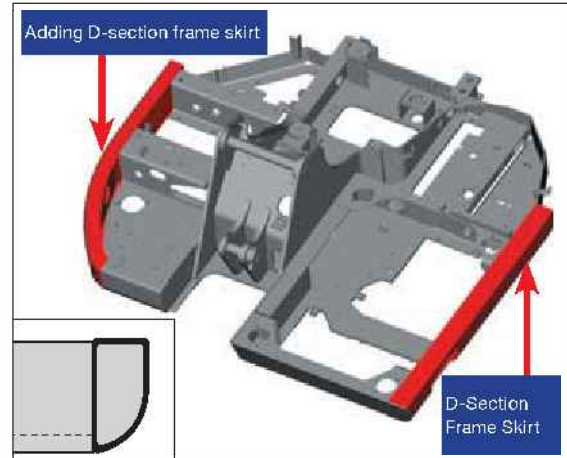

Strengthened X beam

One-piece upper and lower plates are utilized instead of conventional 4-piece plates, eliminating welds. This increases strength of the track frame.

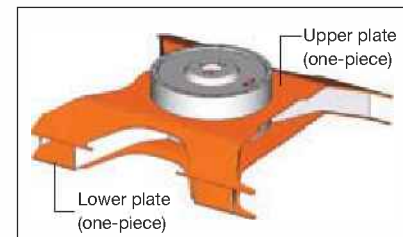

Strengthened front attachment

At arm-bucket joint, the arm top is hardened with WC thermal spraying (Tungsten-Carbide) for greater wear resistance at its contact surface with bucket, reducing jerking.



WC Thermal spraying

Simplified Maintenance

The ZAXIS-3 series meet customer demands for simplified maintenance. Regular maintenance is the key for keeping equipment in top condition, which can help to prevent costly downtime. In addition, a regular serviced machine has higher residual value. There are many service features to be found on the ZAXIS-3 series.



Conveniently located inspection points

Wide doors give access, from ground level, to the fuel filter, water separator and engine oil filter.

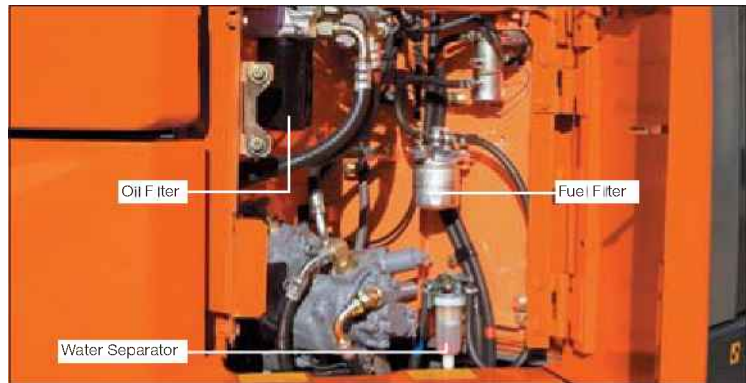

Parallel arrangement of the cooling pack

The oil cooler and radiator are laid out in a parallel arrangement, instead of the conventional in-line arrangement. This parallel arrangement is significantly easier to clean around the radiator.

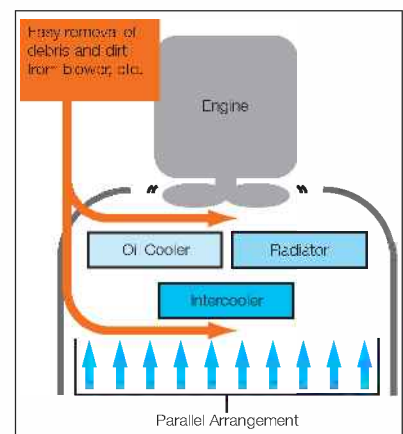

Extended oil and filter change intervals

Front Pin Lubricating Intervals and Consumables Replacement		New ZAXIS 85US
Lubricant	Bucket	500 h
	Boom Foot	500 h
	Front	500 h
Consumables	Engine Oil	500 h
	Engine Oil Filter	500 h
	Hydraulic Oil	5 000 h
	Hydraulic Oil Filter	1 000 h
	Fuel Filter	500 h

The fuel tank is a 135L short-tail-swing version, the same capacity as that used in standard equipment. With 135L, refueling doesn't have to be done as often. The oil and filter change intervals have been extended considerably, reducing maintenance time and expenses. Engine oil consumption is lower. Hydraulic oil can be used up to 5 000 hours.

Safety Features

Ensuring the safety of the operator and other workers on the jobsite is an important concern for HITACHI. That is why the ZAXIS-3 series has a number of safety features including a new reinforced cab and shut-off mechanisms for engine and pilot controls.

CRES II cab

The CRES II cab is designed to help with “just in case” protection for the operator. Safety in case of tipping is improved. The cab top, for instance, can withstand about 1.4 times conventional load when side load is applied to the cab top until its deformation reaches 200 mm.

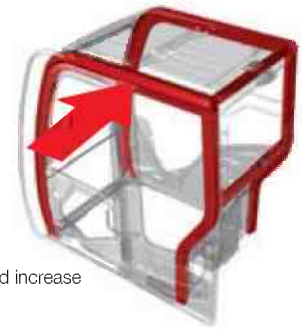

withstanding load: 1.4-fold increase

Additional features

Cab right protection bars



Evacuation hammer



Engine stop knob



Pilot control shut-off lever



OPG top guard, Level II (optional)



Retractable seat belt



Other features include a retractable seat belt, evacuation hammer and emergency engine stop knob. A shut-off lever for pilot control helps to prevent unintentional movements. In addition a Falling Object Protective Structure (OPG top guard, Level II) guard is optionally available. For the cab windows there is a choice of laminated or tempered glass.

Environmental Features

HITACHI acts responsibly when it comes to the environment. Our production facilities have ISO 14001 certification. The HITACHI machine is lead free and has a low-noise design, therefore HITACHI customers get one of the most environmentally considerate hydraulic excavators available today.

A cleaner machine

The ZAXIS-3 series is equipped with a clean but powerful engine to comply with Tier 3, and Stage III A. An engine emission regulations effective in the U.S. EPA and European Union from 2008. Exhaust gas is partly re-combusted to reduce particulate matter (PM) output and lower nitrogen oxide (NOx) levels.



A quieter machine

Many features contribute to noise reduction in the new ZAXIS. Firstly, the fan with linear clutch responds to the engine temperature: the rotational speed of the fan increases smoothly as the temperature of the engine increases. This control reduces noise in light-load operations, as the fan rotational speed does not increase beyond what is necessary. This also means that no load is placed on the engine, reducing fuel consumption. The cylinder block and ladder frame in the new engine are strengthened, reducing engine noise. Due to intercooled turbo charging and the optimization of fuel injection timing, exhaust noise is reduced by 10 dB (compared to previous models).



A recyclable machine

All resin parts are marked to facilitate recycling. The machine is completely lead-free. The radiator and oil cooler are made from aluminium and all wires are lead-less. In addition, biodegradable hydraulic oil is available for jobsites where special environmental care is required.



Reserve dele & Service

I årenes løb har vi oparbejdet erfaring fra ét de mest konkurrenceprægede servicemarkeder i verden - nemlig Japan. Ved hjælp af vores know-how med hensyn til at handle direkte med vores kunder har vi skabt et verdensomspændende supportsystem, der er yderst kompetent.

Reserve dele

HITACHI tilbyder ægte reserve dele af høj kvalitet. Vi garanterer, at disse reserve dele har høj ydeevne og et langt liv. Vi håndterer ca. 1 million reservedelsnumre over hele verden. De er alle præcist tilpasset dit HITACHI-udstyr. Hitachi har et globalt reservedelsnetværk, der sikrer dig hurtigst mulig levering. Vi har mere end 150 forhandlere verden over, og

din lokale forhandler har oftest de nødvendige reserve dele på lager. I modsat fald sikrer fire fuldt lagerførende reservedelscentre en hurtig levering af delen. Hvis en forhandler ikke har en bestemt reserve del, kan han bestille den fra fire fuldt forsynede reservedelslagre, som er fordelt rundt i verden. Disse distributionscentre er alle bundet sammen af et online-

system, som giver dem adgang til fælles information om lagerbeholdning, såsom antal og typer af tilgængelige dele. Lagrene, som forsynes fra et reservedelscenter i Japan, sørger for at minimere leveringstid og gør det muligt for dig at få dine reserve dele så effektivt og hurtigt som muligt.

Service

Det er vores mål at "holde vore kunders maskiner i optimal stand". For at nå dette mål har vi over 150 forhandlere placeret rundt omkring i hele verden. De har højtuddannede teknikere, og de tilbyder en række supportprogrammer. HITACHI har et enestående garantiprogram, som hedder HITACHI

Extended Life Program, eller HELP. For at minimere stilstandstid under fejlfinding har vi udviklet et PDA-baseret fejlfindingssystem, der har fået navnet "Dr.ZX". God service er uundværlig for at holde vore kunders udstyr i topform. Vi tror på, at personaleuddannelse er nøglen til at yde den bedste service.

Spørg venligst den nærmeste HITACHI-forhandler, hvis du ønsker flere oplysninger om reserve dele og/eller service. Ikke alle programmer og/eller services fås ikke på alle markeder eller i alle områder.



Fjern-flådestyring med Global e-Service

Reducer indsatsen og omkostningerne ved vedligeholdelse af din maskinflåde med Global e-Service. Få den nyeste information om hver enkelt af dine maskiner online - i dit kontor.



Global e-Service funktioner

Drift

Fjernadgang til al relevant driftsinformation såsom daglige driftstimer og brændstofniveau såvel som historisk opsamlede oplysninger om temperaturer og tryk.

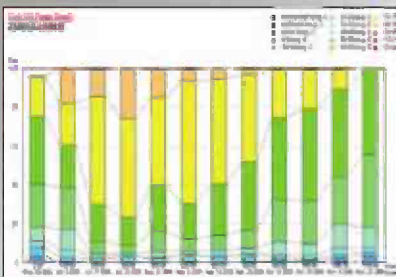

Vedligeholdelse

For hver maskine vil vedligeholdelsehistorik samt anbefalet vedligeholdelse blive vist på en gang, så det er muligt at udføre nøjagtig og effektiv vedligeholdelsesstyring af flåden.

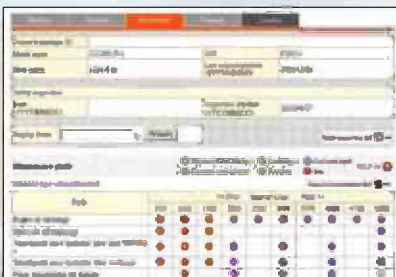

Lokation

Ud over generelle GPS-funktioner, vil GIS-systemet (Geographical Information System) ikke blot vise den geografiske position for hver maskine med øjeblikkelig identifikation af serienummer, det vil også gøre det muligt at søge på flere maskiner ved at bruge specifikke oplysninger om driftsinformation som søgekriterier.

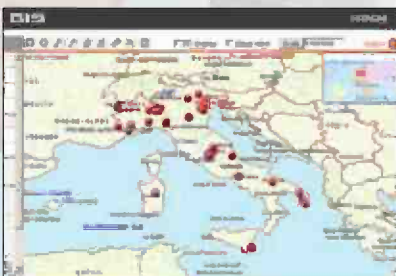

Kontrollér og overvåg hver maskine fra dit kontor

Udvidet service fra din lokale forhandler

Aktuel geografisk location for hver enkelt af dine maskiner

Global e-Service er et online flådestyringsværktøj, som tilbydes af Hitachi til hver enkelt kunde. Det viser al driftsinformation og lokation for dine maskiner på en PC i dit kontor. Derved får du en ajourført oversigt over dine maskiner, så du kan opnå fuld flådekontrol. Hver maskine sender regelmæssigt sine driftsdata derfra til en Hitachi-server. Dataene opsamles i serveren og bliver behandlet og stillet til rådighed for hver enkelt kunde over hele verden. Din maskininformation vil være tilgængelig for dig og din forhandler gennem en sikker internetforbindelse. Kommunikationsforbindelsen er i drift 24 timer i døgnet hver eneste dag i året. Det vil støtte din jobplanlægning, hjælpe dig med at vedligeholde din maskine og give din lokale forhandler mulighed for at udføre udvidet service og hjælp til fejlfinding. Det vil direkte bidrage til at nedbringe stilstandstiden og øge din flådes ydelse i forhold til omkostningerne.

Mange ZAXIS-3 og ZW-maskiner vil have satellitkommunikation installeret som standardudstyr*, hvilket indebærer, at hver enkelt ejer kan drage direkte nytte af Global e-Service. Din lokale forhandler vil kunne give dig adgang til Global e-Service.

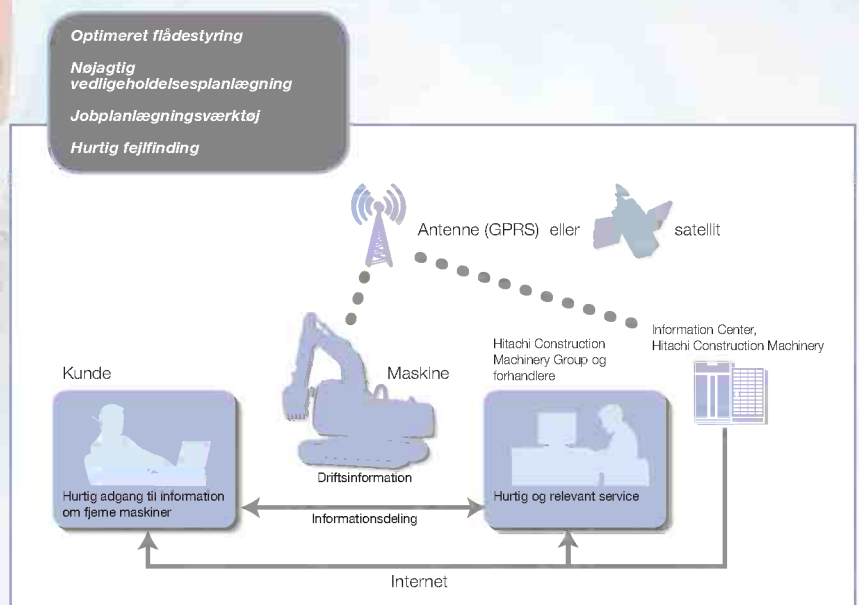

* (1) Satellitkommunikation kan være forbudt ifølge lokale bestemmelser (inklusive sikkerhedsbestemmelser) eller lovgivning i det land, hvor du ønsker at anvende den. Kontakt din Hitachi-forhandler for yderligere oplysninger.
 (2) Satellitkommunikation giver som udgangspunkt verdensomspændende dækning. Kontakt din lokale forhandler og få aktuelle oplysninger om adgang til satellitkommunikation i dit land eller på et bestemt arbejdssted.
 (3) Hvis overførsel af satellitsignalet bliver forhindret på nogen måde, vil satellitkommunikation måske ikke være mulig.
 (4) Kommunikationssystemet for driftsdata varierer afhængigt af model og produktionsdato.

SPECIFICATIONS

ENGINE

Model	Isuzu AU-4LE2X
Type	4-cycle water-cooled, direct injection
Aspiration	Turbocharged, intercooled
No. of cylinders	4
Rated power	
ISO 9249, net	39.4 kW (52.8 HP) at 2 000 min ⁻¹ (rpm)
EEC 80/1269, net ..	39.4 kW (52.8 HP) at 2 000 min ⁻¹ (rpm)
SAE J1349, net	39.4 kW (52.8 HP) at 2 000 min ⁻¹ (rpm)
Maximum torque	215 N·m (21.9 kgf·m) at 1 500 min ⁻¹ (rpm)
Piston displacement ..	2.179 L
Bore and stroke	85 mm x 96 mm
Batteries	2 x 12 V / 52 Ah

HYDRAULIC SYSTEM

- Swing-independent 3-pump hydraulic system
- OHS (Optimum Hydraulic System) assures fully independent and combined operations
- Automatic 2-speed motor increases traction force and travel speed
- Engin speed sensing system

Main pumps	3 variable displacement axial piston pumps
Maximum oil flow ..	2 x 79.2 L/min
	1 x 61.6 L/min
Pilot pump	1 gear pump
Maximum oil flow ..	22.0 L/min

Hydraulic Motors

Travel	2 variable displacement axial piston motors
Swing	1 axial piston motor

Relief Valve Settings

Implement circuit	26.0 MPa (265 kgf/cm ²)
Swing circuit	25.0 MPa (255 kgf/cm ²)
Travel circuit	31.4 MPa (320 kgf/cm ²)
Pilot circuit	3.9 MPa (40 kgf/cm ²)

Hydraulic Cylinders

High-strength piston rods and tubes. Cylinder cushion mechanisms provided in boom and arm cylinders to absorb shock at stroke ends.

Dimensions

	Quantity	Bore	Rod diameter
Boom	1	115 mm	65 mm
Arm	1	95 mm	60 mm
Bucket	1	85 mm	55 mm
Off-Set (optional)	1	105 mm	60 mm

Hydraulic Filters

Hydraulic circuits use high-quality hydraulic filters. A suction filter is incorporated in the suction line, and full-flow filters in the return line and swing/travel motor drain lines.

CONTROLS

Pilot controls. Hitachi's original shockless valve.

Implement levers	2
Travel levers with pedals	2
Blade lever (optional)	1
Off-set front pedal (optional) ...	1

UPPERSTRUCTURE

Revolving Frame

Welded sturdy box construction, using heavy-gauge steel plates for ruggedness. D-section frame for resistance to deformation.

Swing Device

Axial piston motor with planetary reduction gear is bathed in oil. Swing circle is single-row, shear-type ball bearing with induction-hardened internal gear. Internal gear and pinion gear are immersed in lubricant. Swing parking brake is spring-set/hydraulic-released disc type.

Swing speed	10.5 min ⁻¹ (rpm)
Swing torque	16.0 kN·m (1 630 kgf·m)

Operator's Cab

Independent spacious cab, 1 005 mm wide by 1 675 mm high, conforming to ISO* Standards. Reinforced glass windows on 4 sides for visibility. Front windows (upper and lower) can be opened. Reclining seat with armrests; adjustable with or without control levers.

* International Standardization Organization

UNDERCARRIAGE

Tracks

Tractor-type undercarriage. Welded track frame using selected materials. Side frame welded to track frame. Lubricated track rollers, idlers, and sprockets with floating seals. Track shoes with triple grousers made of induction-hardened rolled alloy. Heat-treated connecting pins with dirt seals. Hydraulic (grease) track adjusters with shock-absorbing recoil springs.

Numbers of Rollers and Shoes on Each Side

Upper rollers	1
Lower rollers	5
Track shoes	40

Travel Device

Each track driven by 2-speed axial piston motor through planetary reduction gear for counterrotation of the tracks. Sprockets are replaceable. Parking brake is spring-set/hydraulic-released disc type. Travel shockless relief valve built in travel motor absorbs shocks when stopping travel.

Automatic transmission system: High-Low.

Travel speeds	High: 0 to 5.0 km/h
	Low: 0 to 3.1 km/h

Maximum traction force	71.0 kN (7 240 kgf)
------------------------------	---------------------

Gradeability	70% (35 degree) continuous
--------------------	----------------------------

WEIGHTS AND GROUND PRESSURE

ZX85US-3 with Blade:

Equipped with 3.72 m monoblock boom, 1.62 m arm and 0.28 m³ (SAE, PCSA heaped) bucket.

Shoe type	Shoe width	Operating weight	Ground pressure
Triple grouser	450 mm	7 800 kg	34 kPa (0.35 kgf/cm ²)
	600 mm	8 000 kg	26 kPa (0.27 kgf/cm ²)
Pad	450 mm	7 800 kg	33 kPa (0.34 kgf/cm ²)
Rubber	450 mm	7 800 kg	33 kPa (0.34 kgf/cm ²)
Flat	450 mm	8 000 kg	34 kPa (0.35 kgf/cm ²)

ZX85US-3 with Off-Set Front and Blade:

Equipped with off-set front, 1.62 m arm and 0.28 m³ (SAE, PCSA heaped) bucket.

Shoe type	Shoe width	Operating weight	Ground pressure
Triple grouser	450 mm	8 300 kg	36 kPa (0.37 kgf/cm ²)
	600 mm	8 400 kg	27 kPa (0.28 kgf/cm ²)
Pad	450 mm	8 300 kg	35 kPa (0.36 kgf/cm ²)
Rubber	450 mm	8 300 kg	35 kPa (0.36 kgf/cm ²)
Flat	450 mm	8 400 kg	36 kPa (0.37 kgf/cm ²)

Weights of the basic machines [including 1 380 kg counterweight and triple grouser shoes, excluding front-end attachment, blade, fuel, hydraulic oil, engine oil and coolant etc.] are:

ZX85US-3 6 400 kg with 450 mm shoes

SERVICE REFILL CAPACITIES

Fuel tank	135 L
Engine coolant	10.3 L
Engine oil	12.1 L
Travel device	1.2 L
(each side)	
Hydraulic system	100 L
Hydraulic oil tank	56 L

BACKHOE ATTACHMENTS

Boom and arms are of welded, box-section design. 3.72 m monoblock boom, and 1.62 m arms are available.

Buckets

Capacity SAE, PCSA heaped	Width without side cutters	Weight
0.24 m ³	500 mm	231 kg
0.27 m ³	600 mm	251 kg
0.32 m ³	700 mm	286 kg
0.38 m ³	800 mm	306 kg

SOUND LEVEL RESULTS (2000/14/EC)

LwA: sound-power level of airborne noise

LpA: sound level at operator's station

Unit: dB(A)

	LwA	LpA
ZX85US-3	97	72

SPECIFICATIONS

DIMENSIONS

Unit: mm

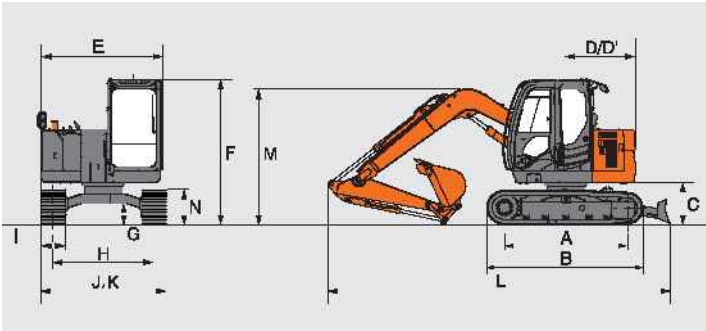

		ZX85US-3
A	Distance between tumblers	2 290
B	Undercarriage length	2 920
* C	Counterweight clearance	*760
D	Rear-end swing radius	1 290
D'	Rear-end length	1 290
E	Overall width of upperstructure	2 250
F	Overall height of cab	2 690
* G	Min. ground clearance	*360
H	Track gauge	1 870
J	Undercarriage width	2 320 / 2 470
K	Overall width	2 320 / 2 470
L	Overall length	
	With 1.62 m arm	6 300
	With 2.11 m arm	6 370
M	Overall height of boom	
	With 1.62 m arm	2 690
	With 2.11 m arm	2 830 (2 690 without Bucket)
* N	Track height with triple grouser shoes	655

* Excluding track shoe lug G: Triple grouser shoe

ZX85US-3 with Blade

A	Overall width of blade	2 320 mm
B	Overall height of blade	460 mm
C	Blade distance	1 880 mm
* D	Max. raising height above ground	360 mm
* E	Max. lowering depth from ground	300 mm

* Excluding track shoe lug

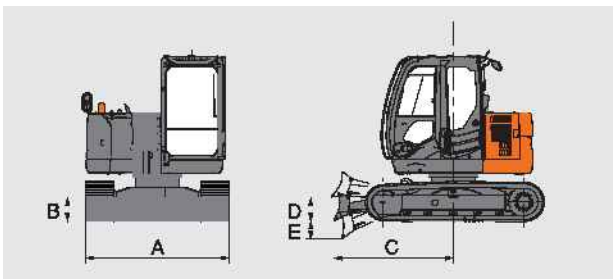

Unit: mm

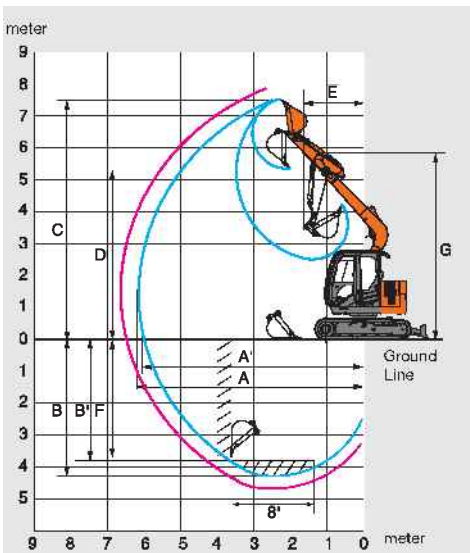

		ZX85US-3	
		1.62 m	2.12 m
A	Max. digging reach	6 430	6 920
A'	Max. digging reach (on ground)	6 260	6 760
B	Max. digging depth	4 110	4 610
B'	Max. digging depth (8' level)	3 760	4 330
C	Max. cutting height	7 210	7 610
D	Max. dumping height	5 120	5 510
E	Min. swing radius	1 810	2 170
F	Max. vertical wall	3 670	4 210
G	Min. swing radius height	5 590	5 610
Bucket digging force ISO		55 kN (5 600 kgf)	
Bucket digging force SAE: PCSA		47 kN (4 800 kgf)	
Arm crowd force ISO		38 kN (3 900 kgf)	32 kN (3 300 kgf)
Arm crowd force SAE: PCSA		36 kN (3 700 kgf)	31 kN (3 200 kgf)

Excluding track shoe lug

DIMENSIONS: OFF-SET FRONT

Unit: mm

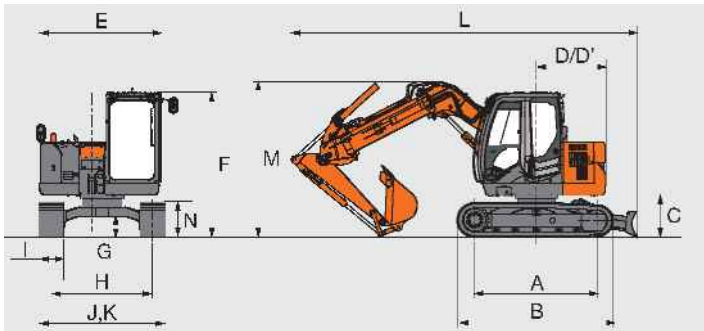

	ZX85US-3	
A	Distance between tumblers	2 290
B	Undercarriage length	2 920
* C	Counterweight clearance	760
D	Rear-end swing radius	1 290
D'	Rear-end length	1 290
E	Overall width of upperstructure	2 250
F	Overall height of cab	2 690
* G	Min. ground clearance	*360
H	Track gauge	1 870
I	Track shoe width	G 450 / G 600
J	Undercarriage width	2 320 / 2 470
K	Overall width	2 320 / 2 470
L	Overall length with 1.62 m arm	6 440
M	Overall height of boom with 1.62 m arm	2 890
* N	Track height with triple grouser shoes	655

* Excluding track shoe lug G: Triple grouser shoe

WORKING RANGES: OFF-SET FRONT

Unit: mm

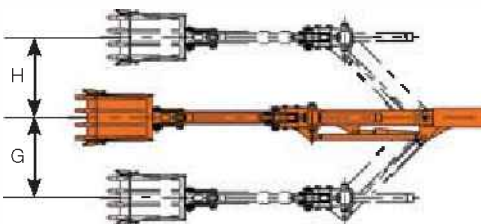

	ZX85US-3		
Arm length	1,62 m		
Off-set distance	0	Max (1 150)	
A	Max. digging reach	6 430	5 980
A'	Max. digging reach (on ground)	6 260	5 800
B	Max. digging depth	4 110	3 650
B'	Max. digging depth (8' level)	3 730	3 260
C	Max. cutting height	7 190	6 830
D	Max. dumping height	5 110	4 750
E	Min. swing radius	2 260	Left: 2 230 / Right: 2 430
F	Max. vertical wall	3 490	3 040
G	Left side off-set distance	-	1 150
H	Right side off-set distance	-	1 150
Bucket digging force ISO		55 kN (5 600 kgf)	
Bucket digging force SAE: PCSA		47 kN (4 800 kgf)	
Arm crowd force ISO		40 kN (4 100 kgf)	
Arm crowd force SAE: PCSA		38 kN (3 900 kgf)	

Excluding track shoe lug

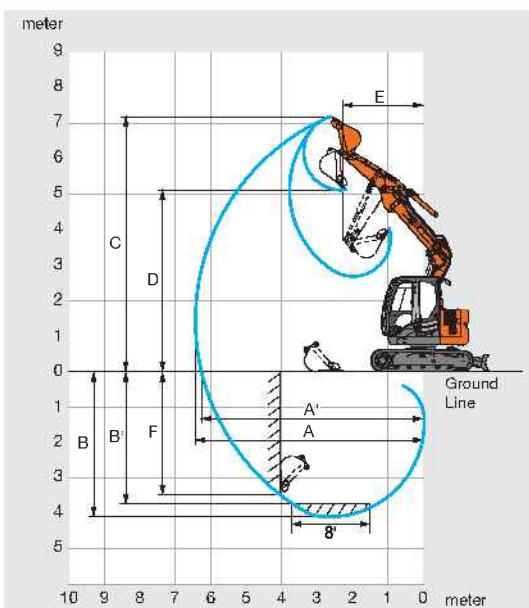

LIFTING CAPACITIES

- Notes: 1. Ratings are based on ISO 10567.
 2. Lifting capacity of the ZAXIS Series does not exceed 75% of tipping load with the machine on firm, level ground or 87% full hydraulic capacity.
 3. The load point is the center-line of the bucket pivot mounting pin on the arm.
 4. *Indicates load limited by hydraulic capacity.
 5. 0 m = Ground.

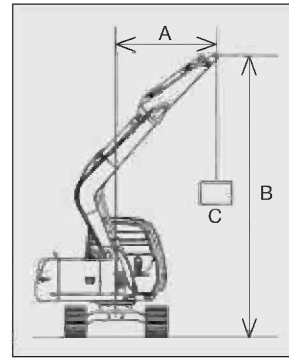

A: Load radius
 B: Load point height
 C: Lifting capacity

ZX85US-3 Monoblock Boom: Blade (Down)



Rating over-side or 360 degrees



Rating over-front

Unit: kg

Conditions	Load point height	Load radius						At max. reach		
		1.5 m		3.0 m		4.5 m		meter		
Boom 3.72 m Arm 1.62 m Counterweight 1 380 kg Grouser Shoe 450 mm	4.5 m			*1 620	*1 620			*1 550	*1 550	4.37
	3.0 m			*2 270	*2 270	*1 840	1 580	*1 490	1 280	5.13
	1.5 m			*3 270	2 700	*2 150	1 510	*1 580	1 170	5.37
	0 (Ground)			*3 690	2 600	*2 370	1 460	*1 870	1 210	5.17
	-1.5 m	*4 370	*4 370	*3 470	2 600			*2 210	1 480	4.46
	-3.0 m							*2 300	*2 300	2.88

Conditions	Load point height	Load radius						At max. reach		
		1.5 m		3.0 m		4.5 m		meter		
Boom 3.72 m Arm 2.12 m Counterweight 1 380 kg Grouser Shoe 450 mm	4.5 m					*1 460	*1 460	*1 300	*1 300	4.96
	3.0 m			*1 870	*1 870	*1 630	1 590	*1 250	1 110	5.64
	1.5 m			*2 930	2 750	*1 990	1 510	*1 310	1 020	5.86
	0 (Ground)			*3 580	2 590	*2 290	1 440	*1 500	1 040	5.67
	-1.5 m	*3 460	*3 460	*3 580	2 550	*2 300	1 420	*1 960	1 220	5.04
	-3.0 m	*5 200	*5 200	*2 840	2 620			*2 130	1 910	3.73

ZX85US-3 Off-Set Front: Blade (Down)

Unit: kg

Conditions	Load point height	Load radius						At max. reach		
		1.5 m		3.0 m		4.5 m		meter		
Arm 1.62 m Counterweight 1 380 kg Grouser Shoe 450 mm	4.5 m			*1 600	*1 600			*1 600	*1 600	4.37
	3.0 m			*2 150	*2 150	*1 670	1 460	*1 610	1 150	5.13
	1.5 m					*1 920	1 330	*1 680	1 000	5.37
	0 (Ground)			*3 230	2 190	*2 070	1 230	*1 780	1 010	5.17
	-1.5 m	*4 010	*4 010	*2 990	2 190			*1 910	1 240	4.46
	-3.0 m							*1 920	*1 920	2.88

EQUIPMENT

STANDARD EQUIPMENT

Standard equipment may vary by country, so please consult your Hitachi dealer for details.

ENGINE

- E mode control
- 50 A alternator
- Dry-type air filter with evacuator valve (with air filter restriction indicator)
- Cartridge-type engine oil filter
- Cartridge-type fuel filter
- Air cleaner double filters
- Radiator, oil cooler and intercooler with dust protective net
- Radiator reserve tank
- Fan guard
- Isolation-mounted engine
- Auto-idle system
- Electrical fuel feed pump with auto stop

HYDRAULIC SYSTEM

- Control valve with main relief valve
- Extra port for control valve
- Suction filter
- Full-flow filter
- Pilot filter
- Swing drain filter

CAB

- CRES II (Center pillar reinforced structure) cab
- OPG top guard fitted Level I (ISO 10262) compliant cab
- All-weather sound suppressed steel cab
- Equipped with reinforced, tinted (green color) glass windows
- 4 fluid-filled elastic mounts
- Front windows on upper, lower and left side can be opened
- Intermittent windshield wipers
- Front window washer
- Adjustable reclining seat with adjustable armrests
- Footrest
- Electric horn
- AM-FM radio with digital clock
- Seat belt
- Drink holder
- Cigarette lighter
- Ashtray
- Storage box
- Glove compartment
- Fire extinguisher bracket
- Floor mat
- Short wrist control levers
- Pilot control shut-off lever
- Engine stop knob
- Auto control air conditioner
- Transparent roof with slide curtain
- Mechanical suspension seat with heater

MONITOR SYSTEM

- Display of meters: water temperature, hour, fuel rate, clock
- Other displays: auto-idle, glow operating conditions, etc
- Alarms: overheat, engine warning, engine oil pressure, alternator, minimum fuel level, air filter restriction, overload, etc
- Alarm buzzers: overheat, engine oil pressure, overload

LIGHTS

- 2 working lights

UPPERSTRUCTURE

- Undercover
- 1 380 kg counterweight
- Fuel level float
- Hydraulic oil level gauge
- Rear view mirror (right, left side & cab rear)
- Swing parking brake

UNDERCARRIAGE

- Travel parking brake
- Travel motor covers
- Hydraulic track adjuster
- Bolt-on sprocket
- Upper and lower rollers
- Reinforced track links with pin seals
- 4 tie down hooks

FRONT ATTACHMENTS

- HN bushing
- WC (tungsten-carbide) thermal spraying
- Reinforced resin thrust plate
- Flanged pin
- Dirt seal on all bucket pins

MISCELLANEOUS

- Standard tool kit
- Lockable machine covers
- Lockable fuel refilling cap
- Skid-resistant handrails
- Travel direction mark on track frame
- Onboard information controller

OPTIONAL EQUIPMENT

Optional equipment may vary by country, so please consult your Hitachi dealer for details.

CAB

- Laminated round glass window
- OPG top guard, Level II
- Air suspension seat with heater
- Rain guard
- Sun visor
- 12 V power source

LIGHTS

- Additional cab roof front lights
- Additional cab roof rear lights
- Rotating lamp
- Additional boom lights with cover

UNDERCARRIAGE

- Track undercover
- Blade (width 2 320 mm / 2 470 mm)
- 450 mm, 600 mm triple grouser shoes
- 450 mm pad shoes
- 450 mm rubber shoes
- 450 mm flat shoes

ATTACHMENTS

- Hammer and crusher piping
- 2 pump combined flow
- Pilot accumulator
- Welded bucket link A with welded hook

OTHERS

- Hose rupture valve
- Overload warning device
- Fuel double filter
- Rear view camera
- Biodegradable oil
- High-performance full flow filter

Prior to operating this machine, including satellite communication system, in a country other than a country of its intended use, it may be necessary to make modifications to it so that it complies with the local regulatory standards (including safety standards) and legal requirements of that particular country. Please do not export or operate this machine outside the country of its intended use until such compliance has been confirmed. Please contact your Hitachi dealer in case of questions about compliance.

These specifications are subject to change without notice. Illustrations and photos show the standard models, and may or may not include optional equipment, accessories, and all standard equipment with some differences in color and features. Before use, read and understand the Operator's Manual for proper operation.



KS-EN092EUQ